

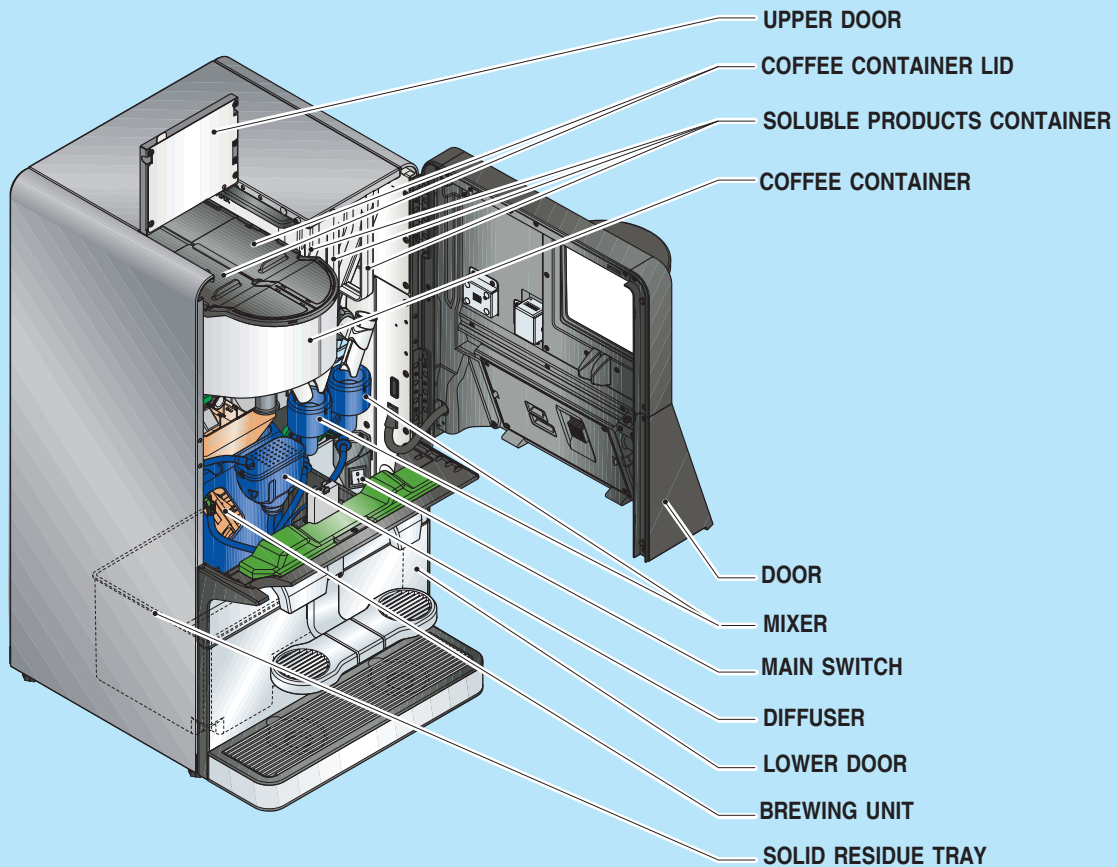

Specific products for coffee machines may be used for cleaning.
Follow the manufacturer's instructions for dosage, method and time of application.

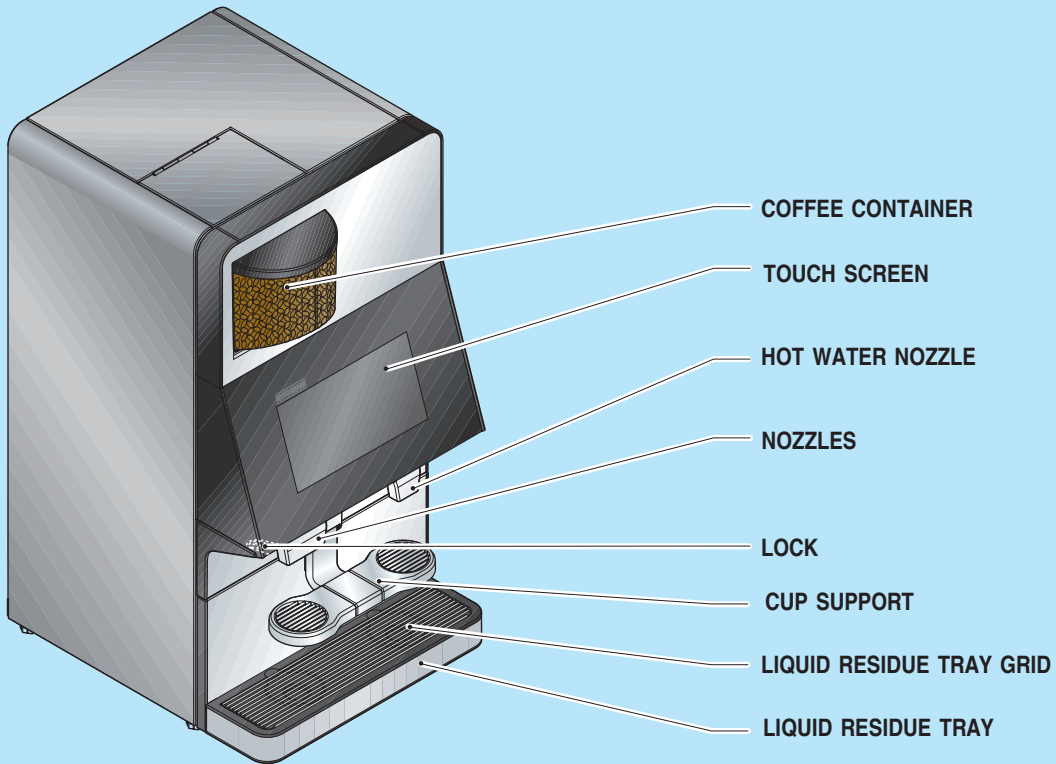

1

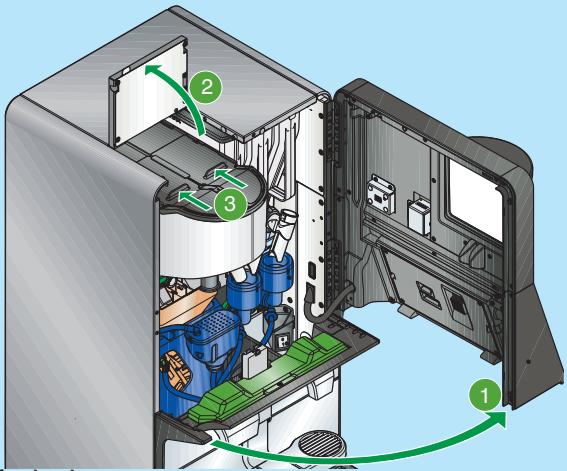

Coffee loader

1. Open the appliance door.
2. Raise the upper panel.
3. Slide the lid off the container and fill with coffee.
4. If container level control is active, indicate the quantity loaded from "daily operations".

2

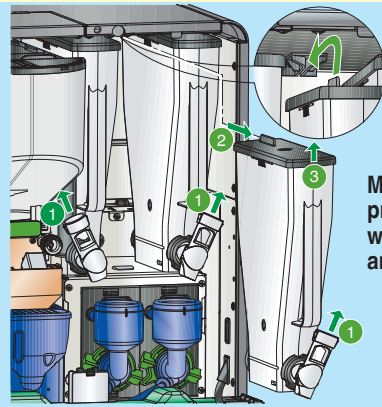

Make sure that the products to be loaded were correctly stored and have not expired

Instant products loader

1. Lift the instant powder conveyor.
2. Remove the container from the shelf.
3. Open the lid and fill the container.
4. Reposition the container, taking care to insert it into the guide.
5. If container level control is active, indicate the quantity loaded from "daily operations".

1

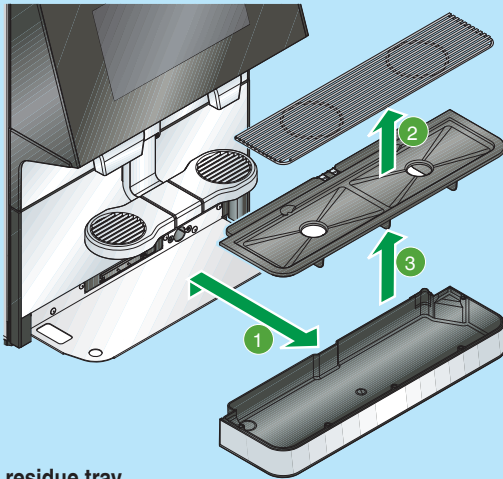

Liquid residue tray

1. Grasp the sides of the liquid residue tray, lift it slightly and pull it out.
2. Separate the parts from the tray and empty the residues; wash the parts with a neutral detergent solution, taking care to remove all residues.
3. Wash the parts.

2

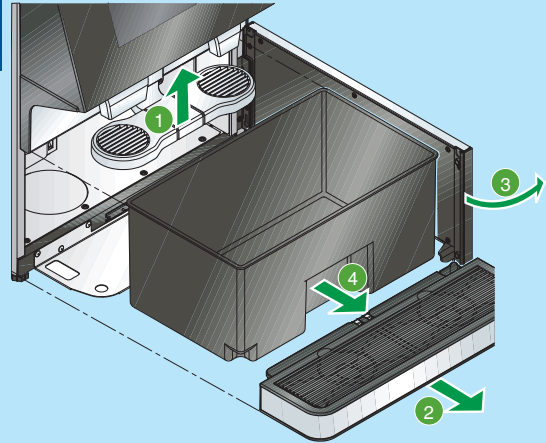

Solid residue trays

1. Lift the cup support upwards.
2. Remove the liquid residue tray.
3. Open the bottom door, remove the solid residue tray and wash it.
4. From the "Daily operations" function reset the counter that manages the "solid residue full" notification.

1

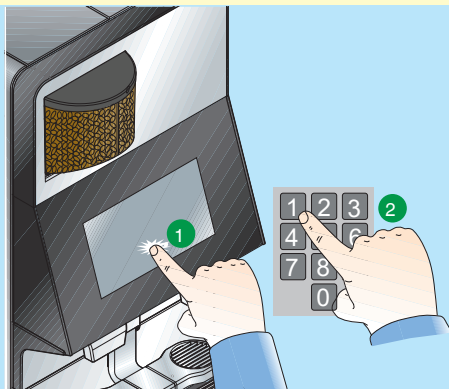

Write down the programmed access password

- The "daily operations" can be accessed in one of the following ways:
- Open the door of the appliance
 - Or if menu-enabled
 - Touch and hold the brand logo for 2 seconds (if enabled in the menu)

2

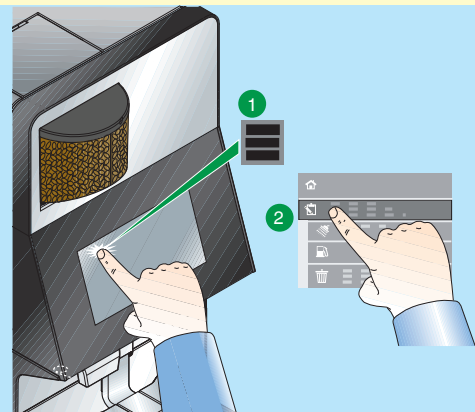

1. Tap to access the menu.
2. Tap the "Daily operations" function.
3. Enter the desired function.
 - Container filling: to indicate the quantity of product loaded.
 - Tray reset: to cancel the "residue full" warning.
 - Washing functions.
4. Tap followed by to exit the menu.

1

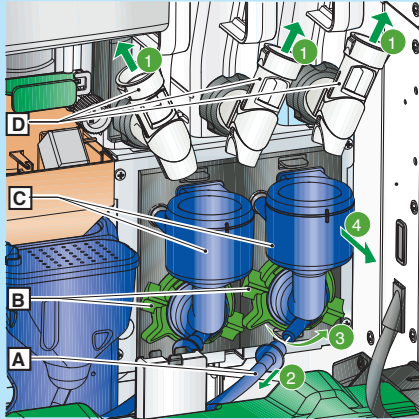

Mixer disassembly

1. Lift the conveyor of the soluble product (D).
2. Detach the tube (A) from the mixer.
3. Turn the fastening lever of the mixer (B) anticlockwise.
4. Remove the mixer (C).

2

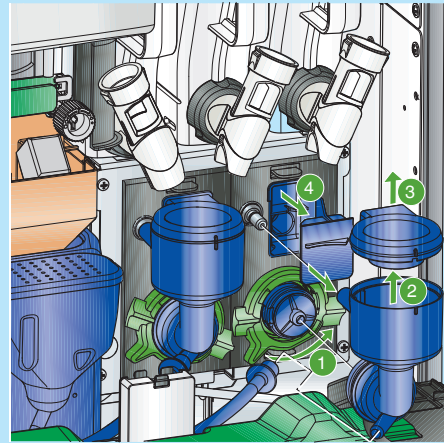

Mixer disassembly

1. Disconnect the tube from the mixer.
2. Turn the mixer fixing lever.
3. Separate all components and proceed with cleaning. Remove visible residues and/or films.

3

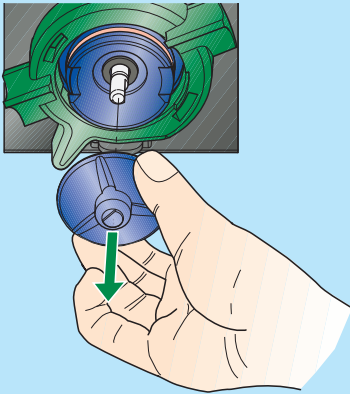

Blender mixer fan disassembly

1. Gently pull to disassemble the mixer fan.
2. Clean the fan and remove visible residues and/or films.
3. Wash and rinse the blue parts under a jet of warm water, using a clean brush and, if necessary, a food-safe detergent.
4. Dry the parts with a paper towel.

4

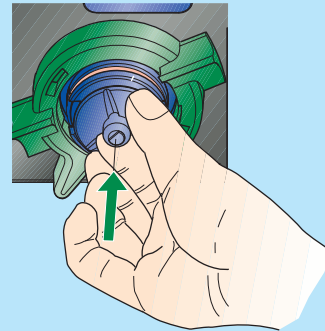

Blender mixer fan assembly

1. Reposition and push the fan of the mixer.
2. Make sure that it is completely inserted until it clicks.

5

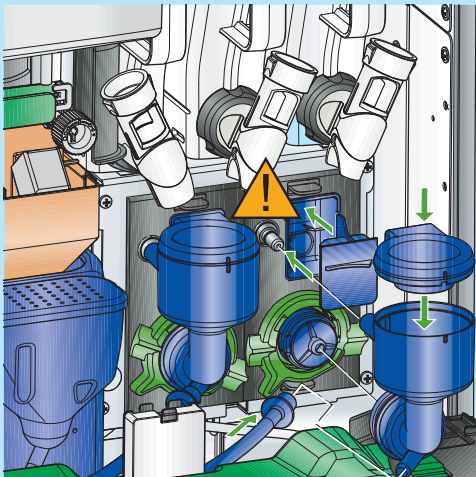

Mixer assembly

1. Reassemble the components and reposition the mixer.

Ensure that the mixer is correctly engaged.

6

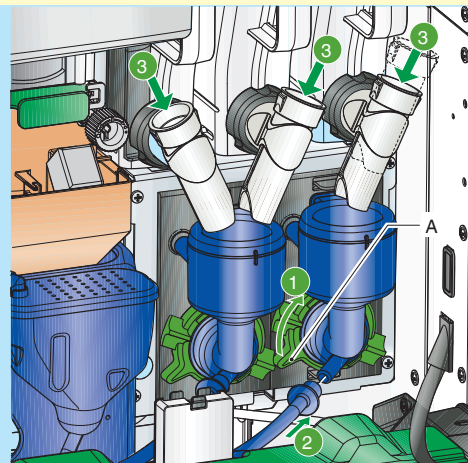

Mixer fastener

1. Turn the lever (A) clockwise to fasten the mixer to the appliance.
2. Reconnect the tubes to the mixers.
3. Lower the nozzles of the instant powders.

7

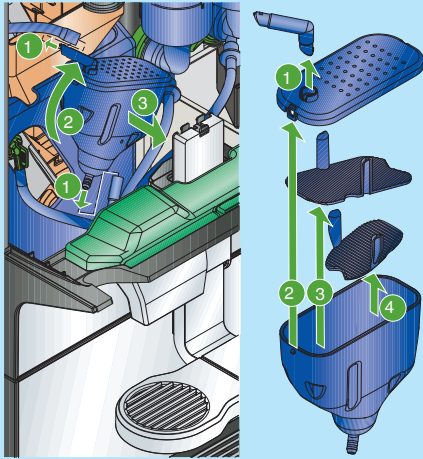

Diffuser disassembly

1. Detach the tubes from the diffuser.
2. Turn the diffuser to the right: the diffuser unhooks from the lid.
3. Separate all diffuser components and proceed with cleaning. Remove visible residues and/or films.

8

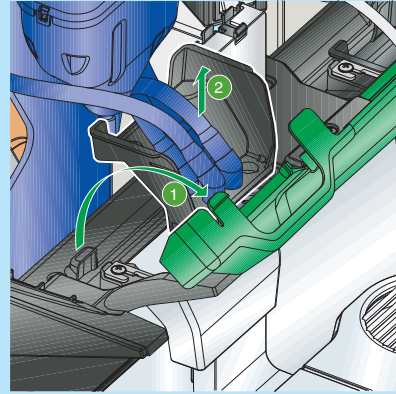

Nozzle disassembly

1. Lifting the lid.
2. Remove the nozzle support (the black part).
3. Disconnect tubes and remove nozzles.
4. Wash and rinse the parts under a jet of warm water, using a clean brush and, if necessary, a food-safe detergent.
5. Dry the parts with a paper towel.

9

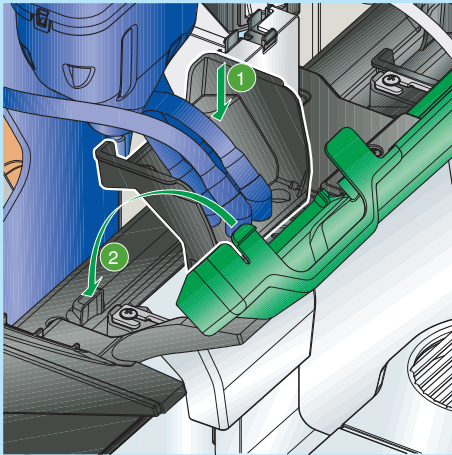

Nozzle assembly

1. Reconnect tubes to nozzles.
2. Insert the nozzles into the support.
3. Reposition the nozzle support.
4. Reinsert the protection lid.

10

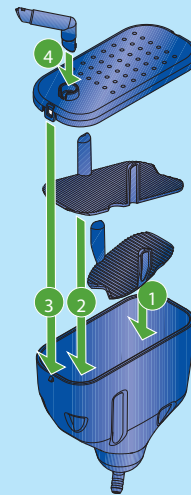

Diffuser assembly

1. After cleaning all components, reassemble the diffuser
2. Fix the diffuser on the lid

11

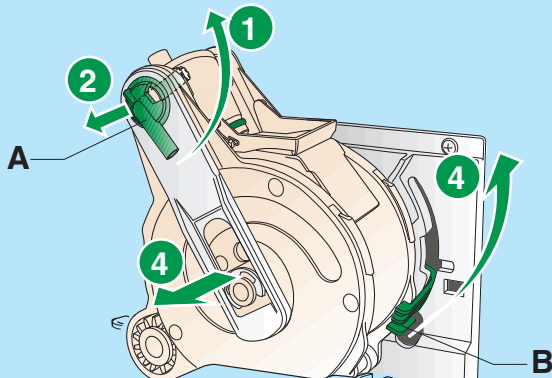

Disassembling and cleaning the brewing unit

1. Turn the coffee output nozzle (A) 90° and pull it towards you.
2. Turn the unit stop lever (B), rotating it until it is in a horizontal position.
3. Remove the brewing unit.

12

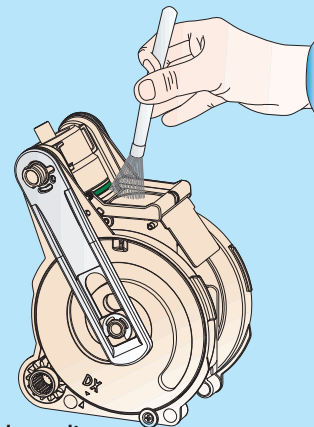

Cleaning the brewing unit

1. With every load or at least weekly, the coffee residues should be cleaned from around the brewing unit.
2. Dust using a small brush or vacuum.
3. Rinse the brewing unit under a jet of water.
4. Reposition the brewing unit following reversing the operations.