

Type <b>Coffee Vending Machine</b>	Model <b>9100</b>	T.I. NO <b>04 - 2017</b>	
Serial Number <b>71412560</b>	Subject <b>NEW DOSING PIPE FOR POWDER CONTAINER</b>	ISSUED FOR (X)	Action Information <b>X</b>

## Reason

The goal of the new **dosing pipes** for powder containers it's to facilitate the extraction or movement of the pipe, during the canister refill.

## Modifications

The **new** dosing pipes differ from the **pre-modification** dosing pipes for the introduction of two stroke stops.

**New dosing pipe**

**Pre-modification dosing pipe**

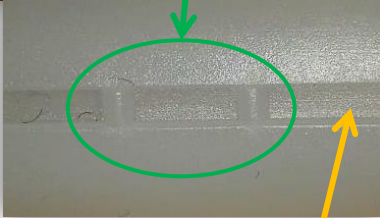

**Modification:**  
*Two stops* have been added along the two tracks.  
 The two stops work with the stops of the **spout**

**Track**

**Spout stop**

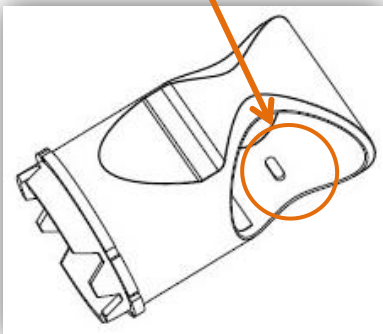
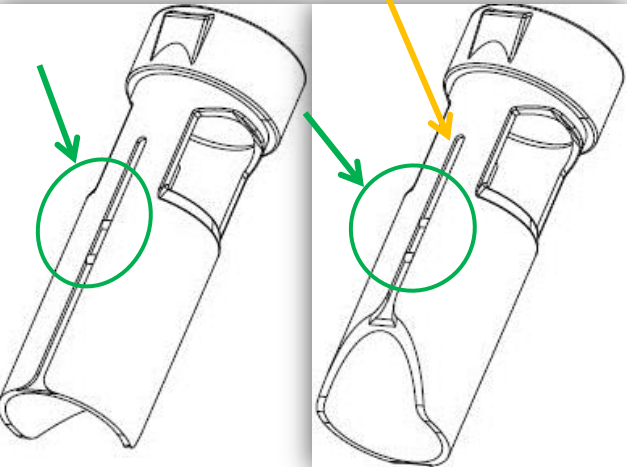

**Spout** (not modified) for dosing pipe  
 The spare code is not changed: **39762200**

# TECHNICAL INFORMATION JDE



Type <b>Coffee Vending Machine</b>	Model <b>9100</b>	T.I. NO <b>04 - 2017</b>		
Serial Number <b>71412560</b>	Subject <b>NEW DOSING PIPE FOR POWDER CONTAINER</b>	ISSUED FOR (X)	Action Information	<b>X</b>

Dosing pipe in **low position**  
Delivery of the powder *allowed*

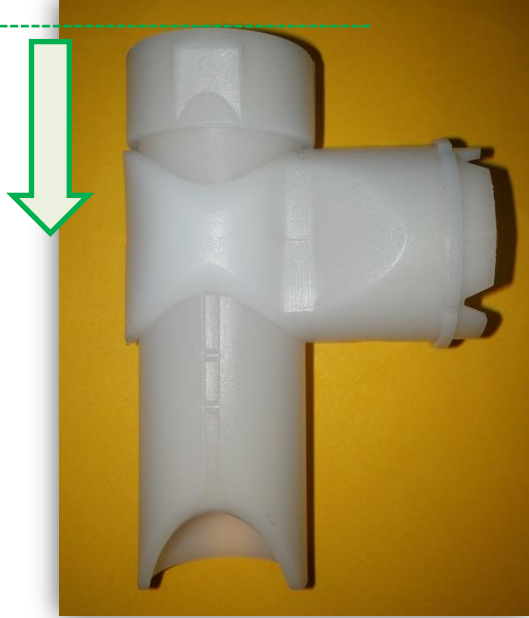

Dosing pipe in **high position**  
Delivery of the powder *not allowed*



In this position the **stops**, added along the two tracks, avoid any accidental removal of the **dosing pipe** from the **spout**

Type <b>Coffee Vending Machine</b>	Model <b>9100</b>	T.I. NO <b>04 - 2017</b>		
Serial Number <b>71412560</b>	Subject <b>NEW DOSING PIPE FOR POWDER CONTAINER</b>	ISSUED FOR (X)	Action Information	<input checked="" type="checkbox"/>

➤ Below the **codes** affected by the modification:

**New dosing pipe** minimum reduction

Spare code: **261229 SAP 55117871**

**Pre-modif. dosing pipe** minimum reduction

Spare code: **39587400**

**New dosing pipe** medium reduction Spare

code: **261230 SAP 55117872**

**Pre-modif. dosing pipe** medium reduction

Spare code: **39762900**

**New dosing pipe** maximum reduction

Spare code: **261231 SAP 55117873**

**Pre-modif. dosing pipe** maximum reduction

Spare code: **259793**

**New dosing pipe** no reduction Spare

code: **261232 SAP 55117874**

**Pre-modification dosing pipe** no reduction

Spare code: **39591600**

**Dosing pipe for tea-brewer**

The spare code is not changed: **260542**

➤ **Machines concerned by this modifications from S/N: 71412560**

## Exchangeability

The **new dosing pipes** can be installed in the machines prior to the SN above.

The **new dosing pipes** replace the **pre-modification dosing pipe** in the container assemblies.

**Note** for the "1,5 L container assemblies" the **new dosing pipe** replaces the **pre-modification dosing pipe + plastic rivet** (see the next page).

Type <b>Coffee Vending Machine</b>	Model <b>9100</b>	T.I. NO <b>04 - 2017</b>		
Serial Number <b>71412560</b>	Subject <b>NEW DOSING PIPE FOR POWDER CONTAINER</b>	ISSUED FOR (X)	Action Information	<b>X</b>

*New solution 1,5 L container assembly :*

the **plastic rivet**, used to remove (or assemble) the *pre-modification* dosing pipe from (with) the **spout**, has been removed.

*1,5 L container assembly with the **new** dosing pipe*

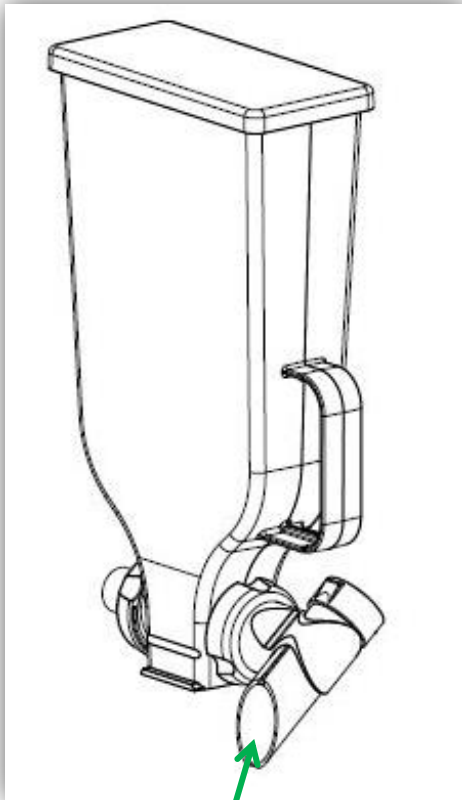

**New dosing pipe** maximum reduction  
Spare code: **261231 SAP 55117873**

*1,5 L container assembly with the **pre-modification** dosing pipe*

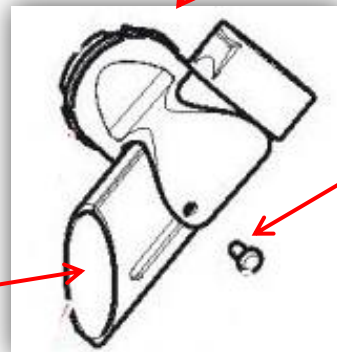
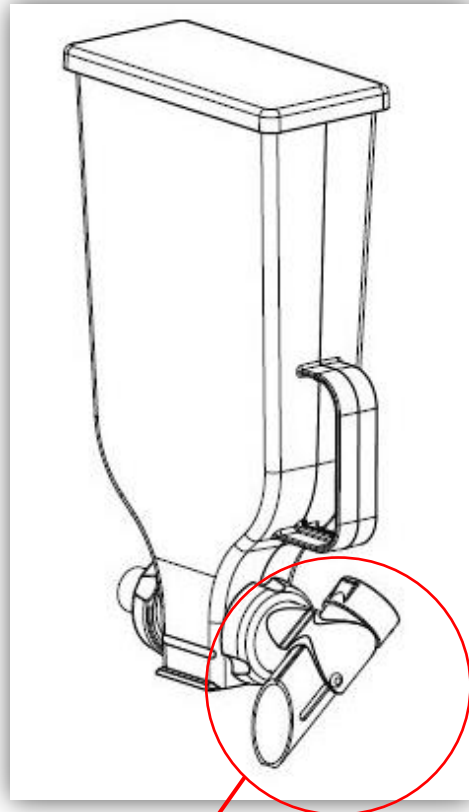

**Plastic rivet**

**Pre-modif. dosing pipe** maximum reduction  
Spare code: **259793**