

| | |
|--|---|
| T.I. no.: 2017 - 04 Updated: - | Topic: Bean hopper locking mechanism and support |
|--|---|

| | | |
|--------------------------------|-----------------|--------------------------------|
| Date: 27/2/2017 | Priority | Need for action |
| Affected machines: SCV | High | As soon as possible |
| From serial number: - | X Medium | X On next visit to the machine |
| As of date: Immediately | Low | FYI only |

SOLUTION TO THE PROBLEM

Optimised closing and locking mechanism for the bean hopper
 The bean hopper can be removed when the closing and locking mechanism cannot be fully opened because beans are jammed in it.

TABLE OF CONTENTS

| | |
|--|----------|
| Solution to the problem | 1 |
| Modified components | 2 |
| Required time..... | 2 |
| Dismantling | 3 |
| Bean hopper supports..... | 3 |
| Counterholder and fastener flaps..... | 3 |
| Installation..... | 4 |
| Counterholder and fastener flaps..... | 4 |
| Bean hopper supports..... | 4 |
| Closing machine | 4 |

MODIFIED COMPONENTS

The following components have been modified:

- A. Counterholder fastener [060642]
- B. Bean hopper support, grinder 1 [060645] and grinder 2 [060646]
- C. Fastener flap [060643]



Required parts per machine

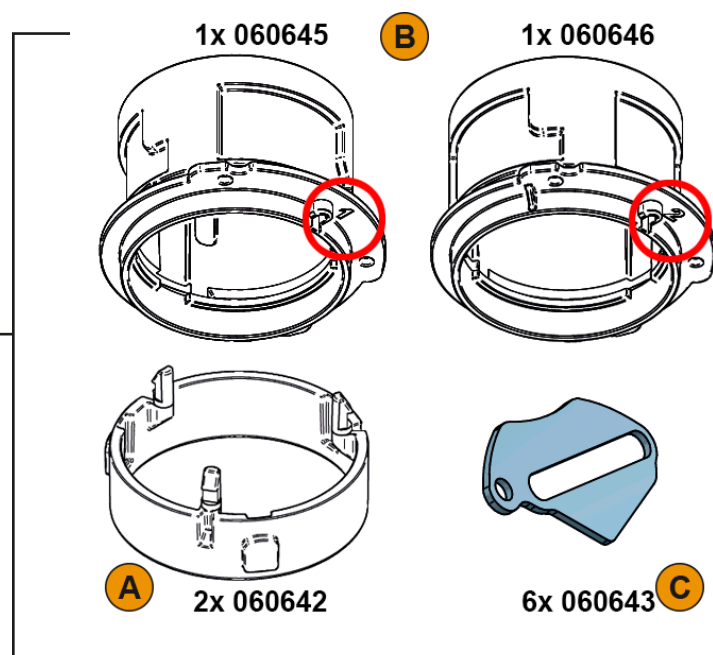

REQUIRED TIME

The time required for replacing the components is about 15-20 minutes.

DISMANTLING

- ▶ Switch off the machine.

Bean hopper supports

- ▶ [1] Remove both bean hoppers and powder container.
- ▶ [2] Remove upper housing section by removing 2x 3 Phillips screws, size PH1.
- ▶ [3] Remove grinder 1 and grinder 2 supports by removing 2x 3 Phillips screws, size PH1.



Counterholder and fastener flaps

- ▶ [4] Using a slotted screwdriver, size 2, carefully lift the three catches.
 - ▶ [5] When all three catches are loosened, the counterholder can be removed upwards.
 - ▶ Repeat steps [4] and [5] for the second bean hopper.
- The fastener flaps of both bean hoppers are accessible for replacement.



INSTALLATION

Counterholder and fastener flaps

- ▶ [1] Insert new fastener flaps [060643] below as shown in the figure.
- ▶ [2] Put on the new counterholder [060642] and push until the three catches engage.
- ▶ Repeat steps [1] and [2] for the second bean hopper.
- ☑ The counterholder and the fastener flaps are now successfully replaced.

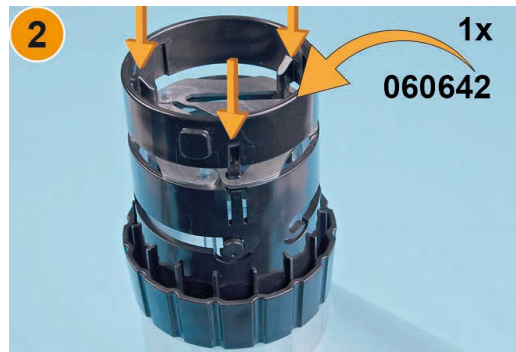

Bean hopper supports

- ▶ [1] Insert new supports for grinder 1 [060645] and grinder 2 [060646] into the machine.
- ▶ [2] Reinstall supports, each with 3 Phillips screws, size PH1.



Do not mix up the supports for grinder 1 and grinder 2. Look at markings [1] and [2] on the component for help, see figure on page 1.

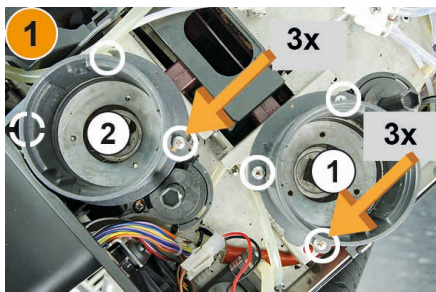

Closing machine

- ▶ [1] Reinstall top housing section with 2x 3 Phillips screws, size PH1.
- ▶ [2] Reinsert bean hoppers and powder container.
- ▶ Switch the machine back on.
- ☑ The machine is ready for use.



(EN) This page is intentionally left blank.

(DE) Diese Seite wurde absichtlich frei gelassen.

(FR) Cette page est laissée vide intentionnellement.

(ES) Esta página se dejado en blanco intencionalmente.