

| | |
|---------------------------------|---|
| T.I. no.: 2025-11 Updated: - | Topic: New device base and power supply |
|---------------------------------|---|

| |
|----------------------------------|
| Date: 2025-10-27 |
| Affected machines: SOUL |
| From production date: 08-06-2025 |
| From date: right away |

| Priority and need for action | |
|-------------------------------------|--------------------------------------|
| <input type="checkbox"/> | High: as soon as possible |
| <input type="checkbox"/> | Medium: on next visit to the machine |
| <input checked="" type="checkbox"/> | Low: FYI only |

NEW BASE PLATE FOR SOUL

A new device base has been introduced for the SOUL. The reinforcement ribs are located on the underside of the new device base. This helps to reduce contamination inside the machine. Due to this change to the device base, the holding plate for the power supply also had to be modified.

The new holding plate for the power supply **3370101584** replaces the previous holding plates **3370060407**, **3370067946** and **3370101545**. The new holding plate combines all connection variants of the three previous models in a single component. The old holding plates are only compatible with the old device base and the new holding plates are only compatible with the new device base.

Design changes to the device base as shown in the figure

Distinguishing feature

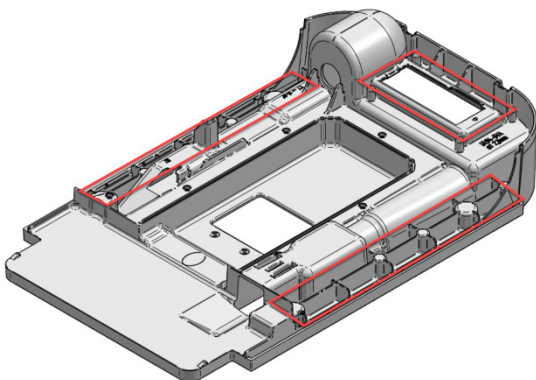

Figure 1: device base old

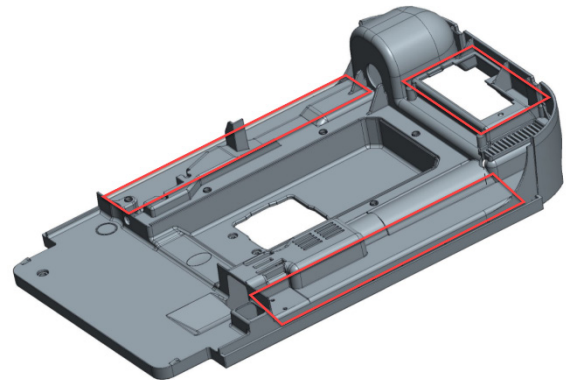

Figure 2: device base new

On the old device base, the reinforcement ribs point upwards.

The new device base has the reinforcement ribs on the underside of the base. Due to this modification, the holder for the holding plate also had to be adjusted.

Design change for the holder for the power supply

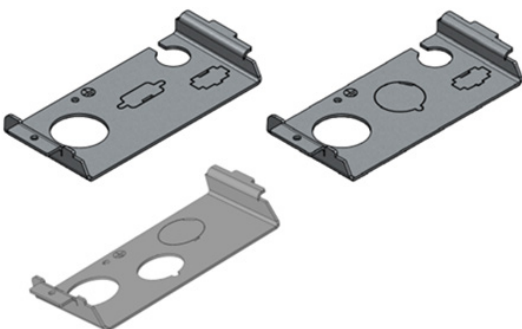

Figure 3: holding plate old

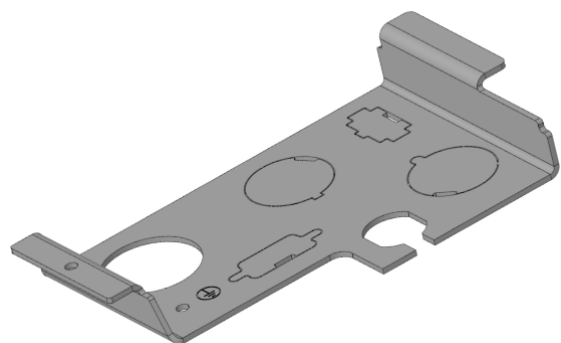

Figure 4: holding plate new

More information

For additional information on the affected machines, contact **Technical Support**:

Service contact

Global Technical Support Team

GBU Professional Coffee Machines

- > Support hotline: +41 32 681 62 75 (10:00-11:30 a.m. CET/3:00-4:30 p.m. CET)
- > Support e-mail: technical-support@schaerer.com